

LF215 Line Filter

All Southwest Microwave products are protected against surges and transients on the input power lines. This level of protection has proved adequate for the majority of exterior installations where electrical activity is infrequent and/or all alarm circuit and power wiring are in buried conduit.

However, in areas where electrical activity is severe, or in installations where alarm circuit or power wiring is not in buried conduit, it is advisable to install a line filter at each sensor to prevent transients on the alarm circuit lines from entering the sensor.

Southwest Microwave, Inc. Model LF215 Line Filter has been designed to provide protection for a two microwave sensors (transmitters, receivers, dual stacked links or transceivers) in areas where high RF fields are present or where severe lightning activity or transients may cause damage in units. The filter is intended to be used with any 12-14V DC powered Southwest Microwave sensor.

The line filter box is separated into two compartments as shown in the Mechanical Configuration in the following figure. The input compartment contains a terminal strip to which the input wires are connected. It is recommended that a #10 buss wire be connected between the ground lug within this compartment and the chassis of the battery box in order to insure that a good connection is established. The second compartment is a RF tight enclosure when the cover is installed. The shielded output cable should be run in ½ inch flexible conduit to the microwave sensor and the appropriate connections made to the terminal strip within the sensor. Ground the shield within the sensor to one of the mounting screws. Note: The LF215 line filter was designed for mounting inside a weatherproof enclosure such as Southwest Microwave Model BX20 or Model BX35.

A Schematic Diagram of the line filter box is shown in the following figure. The metal plate separating the two compartments forms a barrier to any RF signals that might be present on the input lines. The top cover contains a RF gasket that provides a ground path from the plate to the chassis. The plate contains filter feed-through on each line that conduct RF signals present on these lines to ground. In addition to the RF feed-through, lightning and transient suppressor diodes are connected to the input terminal strip through #30 gauge buss wire. This wire acts as a fusible link that opens in the event of a large current due to a lightning strike.

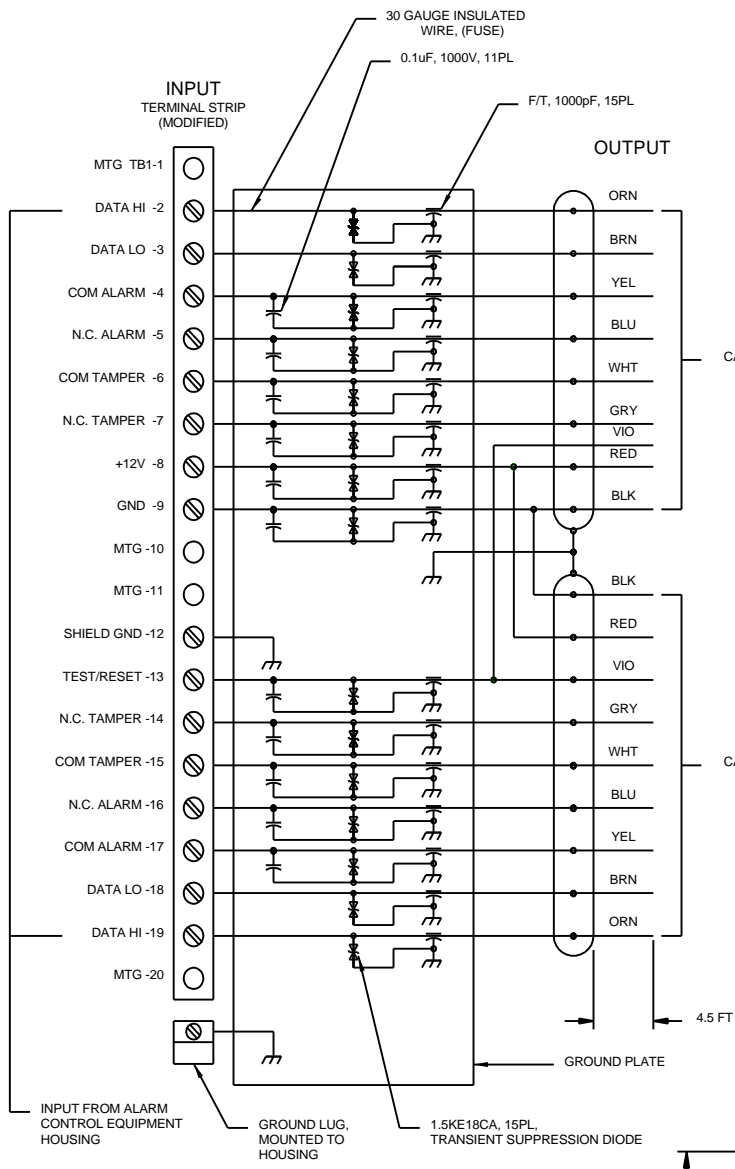

SCHEMATIC DIAGRAM

HEIGHT WITH COVER 2.20 IN
 WEIGHT 2 LBS

Note 1: This line filter is designed to be used on lines carrying DC voltages and/or very low frequency signals such as relay closures. If data or high frequency signals are to be used on any line, the 0.1 uF capacitor may have to be removed to increase bandwidth. Four lines have been dedicated for data.

Note 2: The bi-directional transorbs are rated at 18V breakdown. If signals over 15V are used, please consult the factory.

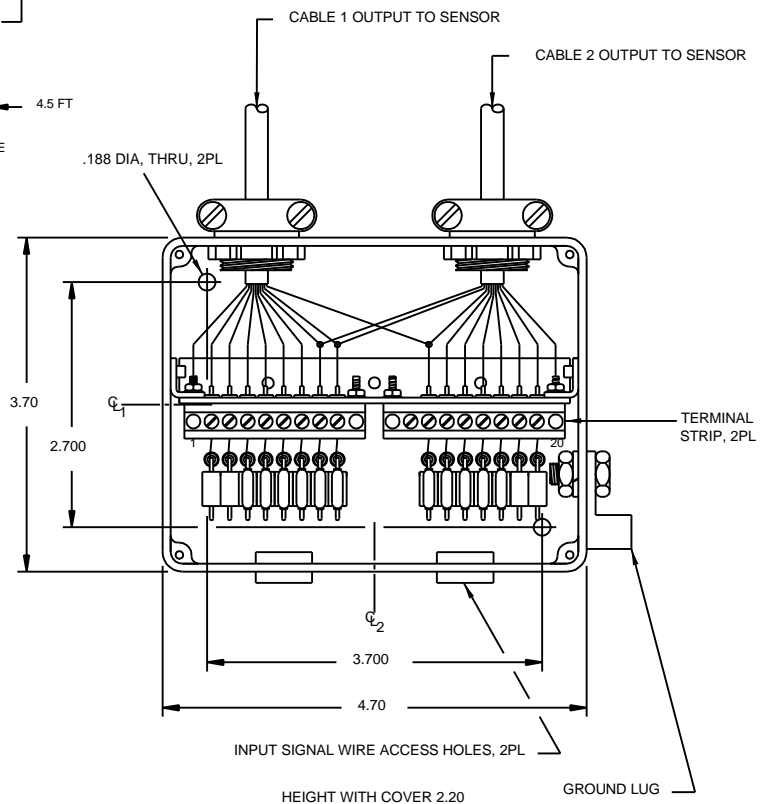

MECHANICAL CONFIGURATION